



Model shown:
BCR3626BVECE

4WD - Professional use
Ideal for rough terrain, hillsides and high vegetation

Outback® Series

BCR3626BVECE, BCR4326BVECE

Billy Goat Outback® ride-on brushcutters have set the highest standard for professional brush cutting equipment on the market. The Outback® 4WD Rider offers unique features and benefits to combat the most demanding conditions.

When rough and overgrown areas limit the use of conventional mowers, this robust machine delivers the ultimate performance for these conditions.

The Outback® 4WD Rider has been designed with a low center of gravity in combination with a four wheel drive system that enables it to tackle those hard-to-reach places that wouldn't have been accessible to traditional machines.

The spacious platform provides sufficient space and comfort for the operator. The heavy duty mower deck is equipped with swing-back cutter blades that swing away when accidental contact is made with a solid object. These features help to protect the mower deck and cutter blades from accidental damage.

Look no further than the Billy Goat Outback® when you are looking for the ultimate brush cutting machine.

VANGUARD®



Vanguard™ EFI engine

By adding closed-loop EFI, Vanguard™ engines deliver easier starting and fuel savings of up to 25%* over carburetted equivalents. Vanguard™ EFI systems also deliver optimized starting, including cold & hot restart and chokeless starting.

* Closed-loop EFI system fuel savings may vary based on cutting conditions and other factors.



Features

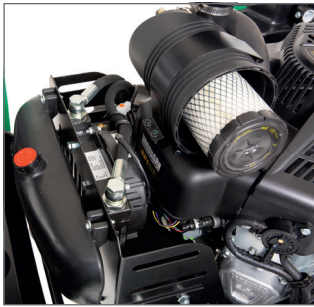

Transmission Oil Cooler

A remote transmission oil cooler controls the transmission oil temperature even in the toughest conditions, reducing thermal oil breakdown for an extended operating life of the system.



ROPS Structure

A certified ROPS (Roll Over Protection Structure) with safety belt protects the machine and operator for rolling over and can fold 180 degrees backwards to allow for easier loading inside a van or trailer.



User Friendly Dashboard

The operators compartment features a dashboard with control and warning lights, electric PTO engagement switch with soft start function, steering wheel with tilt-function and spinner knob, cruise control switch and a parking-brake lever.

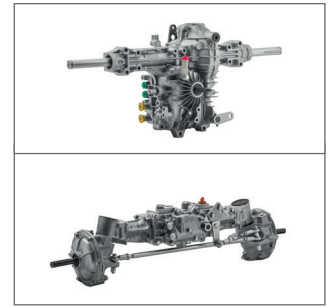

Drive System

The Tuff Torq™ 4WD system automatically controls the output to all drive wheels. Combined with a manual locking differential, this 4WD system provides all the traction you need in challenging terrain.



Durable Mower Deck

The strong fabricated rear discharge deck discharges grass clippings rearwards. Replaceable swing-back cutter blades reduce accidental blade damage, with flip-up lids on the side of the deck providing easy access to the swing-back cutters when needed.



Drive Wheels

Large drive wheels with agricultural tread ensure sufficient grip. The pivoting front axle allows all four driven wheels to remain in contact with the ground for maximum traction.

USE / LEVEL	ROUGH TERRAIN, HILLSIDES & HIGH VEGETATION	
	Outback® Series	
	BCR3626BVECE	BCR4326BVECE

ENGINE

Engine Make / Model	Briggs & Stratton Vanguard™ 810cc EFI, V-Twin	Briggs & Stratton Vanguard™ 810cc EFI, V-Twin
Engine Performance	26 gross HP (SAE J1940) / 810cc*	26 gross HP (SAE J1940) / 810cc*
Air Filtration	Donaldson® 2 stage cyclonic air cleaner	Donaldson® 2 stage cyclonic air cleaner
Fuel	Petrol (up to 10% ethanol)	Petrol (up to 10% ethanol)
Fuel Tank Capacity	16 Litre	16 Litre

BRUSHCUTTER

Cutting Width (cm/inch)	92 / 36"	110 / 43"
Height of Cut (cm)	5 - 13,5 cm (in transport mode max. 16 cm)	5 - 13,5 cm (in transport mode max. 16 cm)
Height Adjustment	Adjustable in 5 positions, one transport position	Adjustable in 5 positions, one transport position
Drive System	Tuff Torq 4WD system with K664 hydrostatic transaxle and KXH10M front axle	Tuff Torq 4WD system with K664 hydrostatic transaxle and KXH10M front axle
Transmission Cooling	Remote Oil Cooler with Electric Fan	Remote Oil Cooler with Electric Fan
Parking Brake	Internal Transaxle	Internal Transaxle
PTO Clutch	Warner Electro Magnetic Clutch	Warner Electro Magnetic Clutch
Deck Drive System	B-section Belt with Soft Start Function	B-section Belt with Soft Start Function
Forward Speed (km/h)	0 - 9,5	0 - 9,5
Reverse Speed (km/h)	0 - 7,5	0 - 7,5
Differential Lock	Standard, Lever Activated	Standard, Lever Activated
Front Wheel (inch)	16 x 6,50 - 8, agricultural tread	16 x 6,50 - 8, agricultural tread
Rear Wheel (inch)	20 x 10,00 - 8, agricultural tread	20 x 10,00 - 8, agricultural tread
Seat	Adjustable Contoured Seat with Armrests and Seat Belt	Adjustable Contoured Seat with Armrests and Seat Belt
Lights	Halogen Front Lights and LED Contour Light Front and Rear	Halogen Front Lights and LED Contour Light Front and Rear
Display Control Lights	Mower Deck Engagement, Parking brake, Oil Pressure, Battery, Fuel Level Warning, Cruise Control, Hour Meter	Mower Deck Engagement, Parking brake, Oil Pressure, Battery, Fuel Level Warning, Cruise Control, Hour Meter

OTHER INFORMATION

Length x Width x Height (mm)	2350 x 1040 x 1740	2350 x 1160 x 1740
Ground Clearance (mm)	125	125
Wheel Base (mm)	1480	1480
Minium Turning Radius (mm)	1280	1280
Rear Wheel Internal Radius (mm)	750	750
Weight (kg)	403	412
Maximum Inclination (°)	22	22

* All power levels are provided by Briggs & Stratton.