



SMART ELECTRIC UTILITY VEHICLES

TECHNICAL SHEET



Made in Belgium

MT15n Tipper

MT15n Tipper

TECHNICAL SHEET

Technical data

Homologation	N1
Seats	2
Speed	Up to 70km/h*
WLTP	Up to 132km*
Turning radius	4,5m
Weight chassis cabin	886kg
Load capacity	779kg
Towing capacity	1200kg**
Brakes front & rear	Discs
Suspension front & rear	Coiled springs
Vehicle warranty	2 years

Electrical data

Motor type	Three fase asynchronous
Motor power	12,5kW
Motor torque	120Nm
Battery type	LiFePO4
Battery capacity	14,4kWh
Battery warranty	5 years
Charging	16A 230V

Dimensions

A - Total length	3655mm
B - Total height	1990mm
C - Cabin width	1390mm
D - Cabin height	1990mm
E - Wheel base	2040mm
F - Front overhang	1065mm
G - Rear overhang	550mm
H - Length tipper	2150mm
I - Height tipper	1350mm
J - Width tipper	1450mm
Internal length tipper	2090mm
Internal width tipper	1380mm

* depending on the chosen transmission and/or local legislation

** 565kg for unbraked trailer

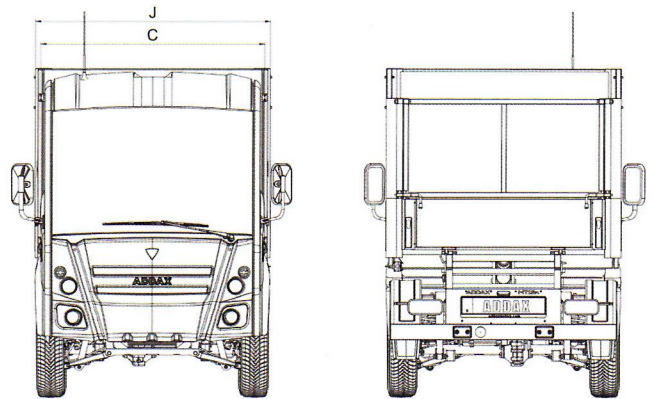
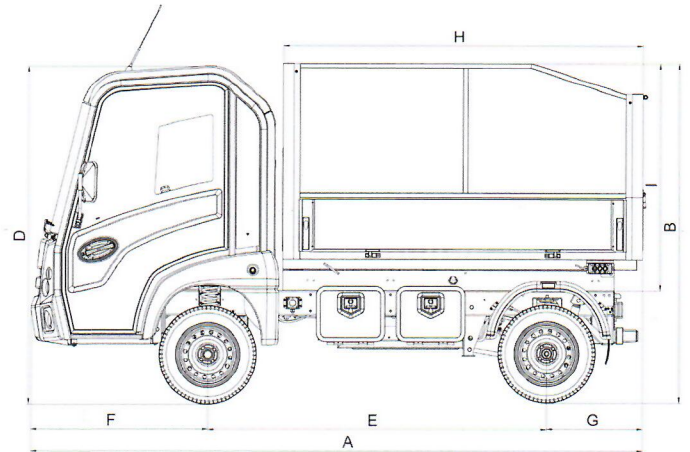

Addax Motors - Kleine Tapuitstraat 18 - 8540 Deerlijk - Belgium - info@addaxmotors.com - +32 56 36 50 00
www.addaxmotors.com

This marketing support presents the models, equipment features and configuration possibilities of Addax electric utility vehicles. All the characteristics of this document are given as and indication. Addax Motors reserves the right to modify them without notice. Visuals may include standard or optional equipment and accessories depending on the country of sale. Technical specifications correspond to standard versions which may differ according to the country of sale. Please check with your dealer for any local specifications.