

Bio Chopper Mixers SAM 7 400-50T Series > Trailed Version

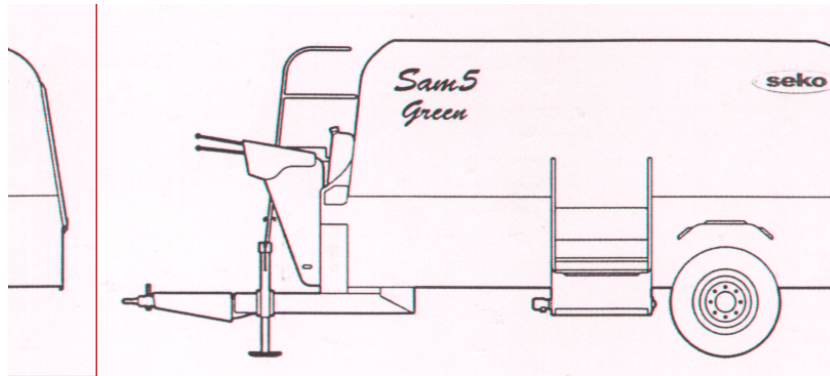

- Trailed Bio Chopper Mixer for green and biological residuals.
- With 2 chopping and mixing spiralled shafts of high strength steel.
- Left side discharge, 900 x 2000 conveyor with hydraulic lifting.
- Preparation for second discharge
- Hydraulic couplings to the tractor with 3 x cable controls
- Epicycloidal gearbox with coupler
- Reverse gear for spiralled shafts
- Rear loading chute
- Frame made of high strength steel
- Turning chopping star shaped blades.
- Dented, demountable and adjustable counter blades
- Adjustable draw-bar
- Mechanical standing foot
- Demountable mudguards
- weighing system
- Inspection access ladder
- Mechanical and hyd brakes
- Road lights
- P.T.O shaft c/w safety bolt

Seko Sam 7 400/50 Trailed 5m³ capacity

Terms

Payment on order

Delivery within 100 mile radius of our depot included - U.K mainland delivery with additional proportional charge.

12 months manufacturers' warranty

01844 299037 - www.rtmachinery.co.uk

Standard company terms and conditions apply

Offered subject to remaining unsold E&OE