

M-Trac 2.0 Walk-Behind Multitool



MADADOR[®]
MADE IN HOLLAND

M-Trac | the 100% electric Walk-Behind Multitool

Care about the environment,
care about ergonomics, health
and people. For those who
deserve the best.



M-Trac 2.0 is your every day, walk behind or sit behind, indoor- and outdoor compact tool. Connect the M-Trac to all types of universal tools. With the universal attachment adaptor, you turn the M-Trac into a snow plough, a lawn mower, a harrow, a city-cleaner, a leaf blower and more!

This 100% electric two-wheel carrier with zero % noise, vibration, and emissions, is the new tool for every citycleaner, gardener, farmer, or greenkeeper. M-Trac is the perfect buddy for maintaining:

- Greenhouses
- Warehouses
- Malls
- Event Halls
- Holiday resorts
- Graveyards

100%
electric | **0%**
emission, noise
or vibration

Spring



- 14501 – Mowing Bar Machine MA-80
- 14502 – Cutterbar UM-137
- 13705 – Double Gyration Grader KP-125
- 14056 – Weed Extractor with trim lines

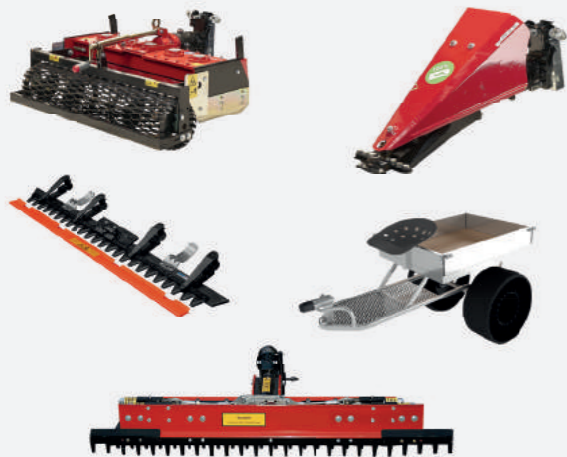

Summer

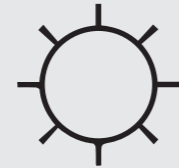

- 14282 – Pathway Weeder WP-90
- 13892 – Weed Extractor WB-60 (single)
- 14036 – Weed Extractor WE-90 (double)
- 14500 – Sickle Mulching Machine VS-L-VS-80
- 14352 – Vertical Flail Machine VS-80



Autumn



- 14833 – Leaf blower
- 14503 – Combi Sweeper KM-120-combi



Winter



- 14506 – Snowplough RS-150
- 14504 – Combi (snow) Sweeper BU-GROB
- 14505 – Combi (snow) Sweeper BU-FEIN
- 14507 – Snow Thrower SE-100
- 14508 – Salt, Gravel and sand spreader SA50-400



Multi-terrain All-rounder

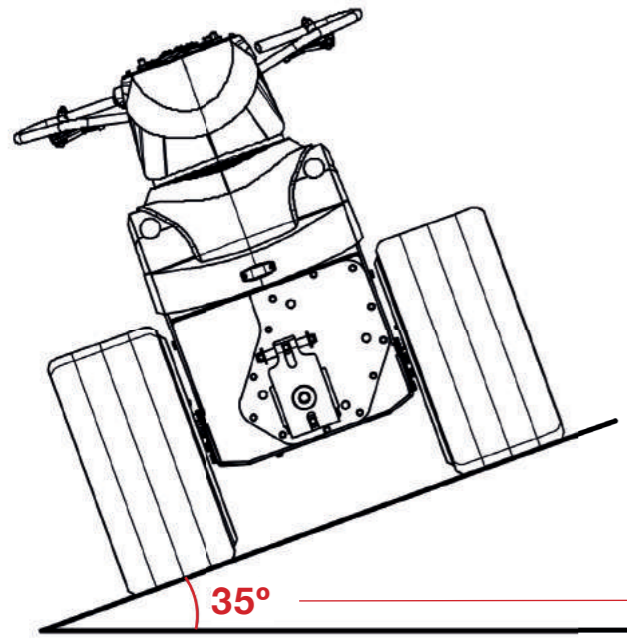

Steep hills or bumps are no problem up to an angle of inclination of 35°

Maximum width 880mm

880mm

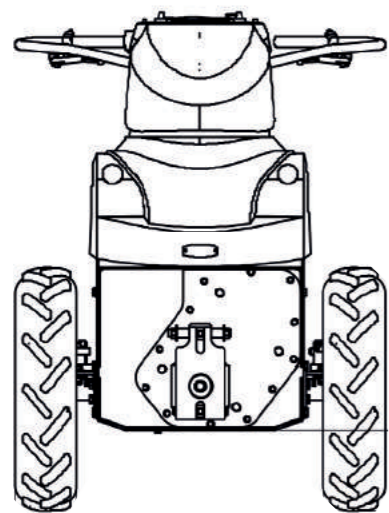
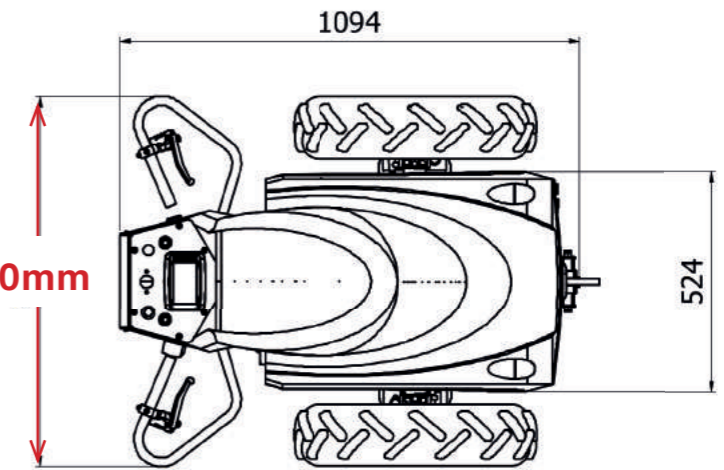

Extreme compact steering with electric height adjustable handle (horizontally and in height)

Angle of inclination 46°

Entry angle 45° (comparable to a Landrover Defender!) depending on wheel diameter

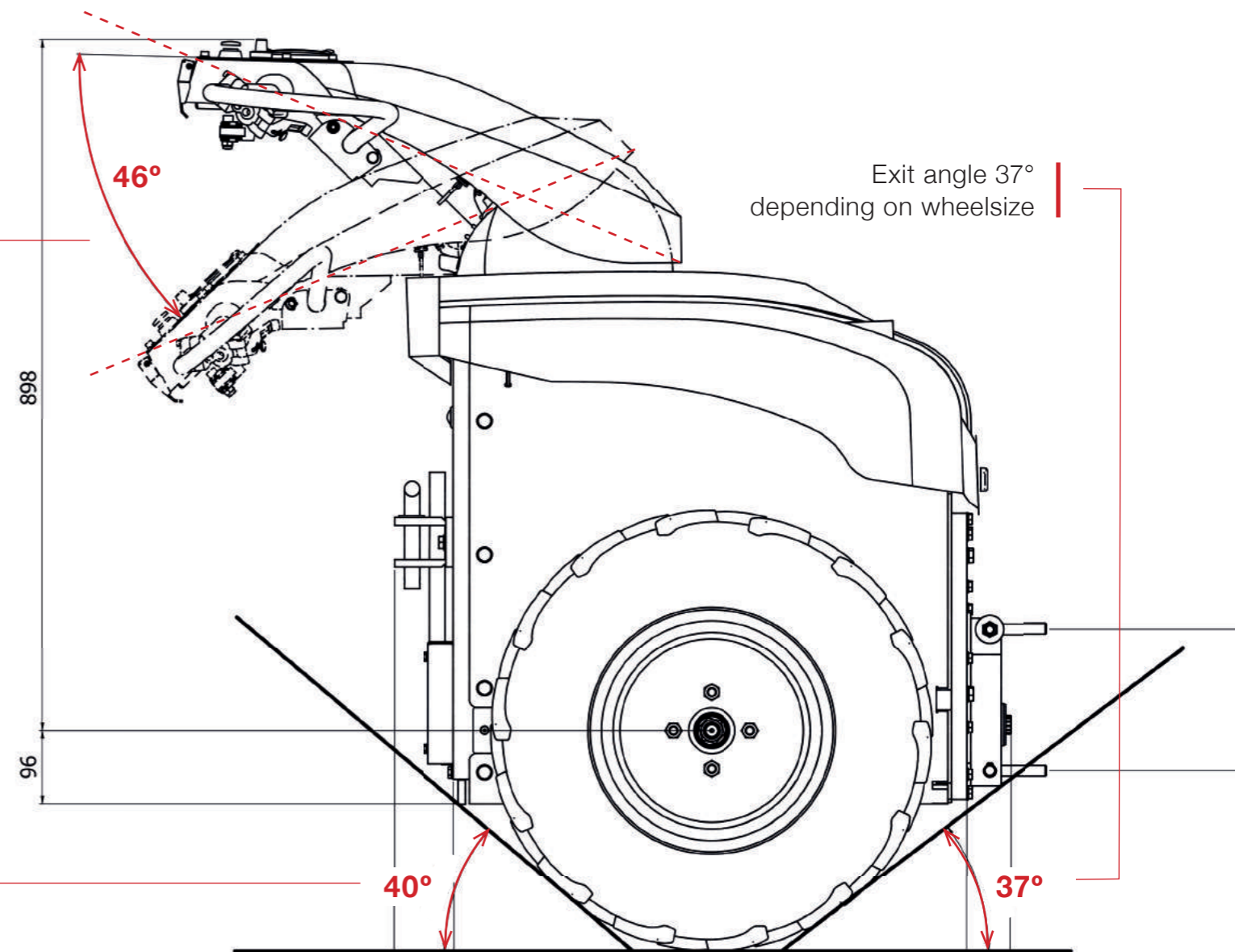

Work with me.

Technical specifications



Item Number	12671 (60 AH) / 13212 (120 AH) / 13244 (180 AH) / 13245 (200 AH)
Product name	M-@M-Trac 2.0
Total size (LxWxH)	1094x880x1186mm
Weight	239 Kg. (without wheels)
Voltage	48 Volt
Battery	Li-ion battery with integrated BMS Multiple battery sizes available
Power	7HP for drive / 10 to 30HP depending on configuration
Max speed	Max. speed 6 km/h, depending on tire size. (reverse = half speed) Electronic speed limitation
Throttle	infinitely adjustable with user definable limiter
Safety	Emergency stop and Belly-switch Entrapment safety in reverse
PTO rpm	Variable 0-1000 rpm Electronically controlled
Handle	Horizontal adjustable - 45 °/ 0 °/ + 45°
Lights	Options for lights on the front/rear, work lights and led-safety lights
Body	Aluminum
Type Coupling	Multiple adapters available
Charger	On-board
Re-charges in	1-10 hours depending on configuration
Display	4,3"
Brakes	Hydraulic disc brakes & E-Motor
Peculiarity	Patented / CE – Patent number: 2017010 (re)charging with M-powervolt



M-Powervolt



Charger and batteries (up to 200 Ah) are always on board and can be equipped with a multi brand connector or adapters.

- ✓ Several days endurance
- ✓ Use M-Powervolt as a powerbank
- ✓ 8kWh capacity
- ✓ Multitool adapters available
- ✓ Noiseless and emission-free energy source.
- ✓ Suitable for indoor and outdoor use
- ✓ Mobile, movable by 1 person
- ✓ 230V/400V 3 phase
- ✓ Compact



Available colors:

RAL9006

RAL5004

Multitool in every sense of the word

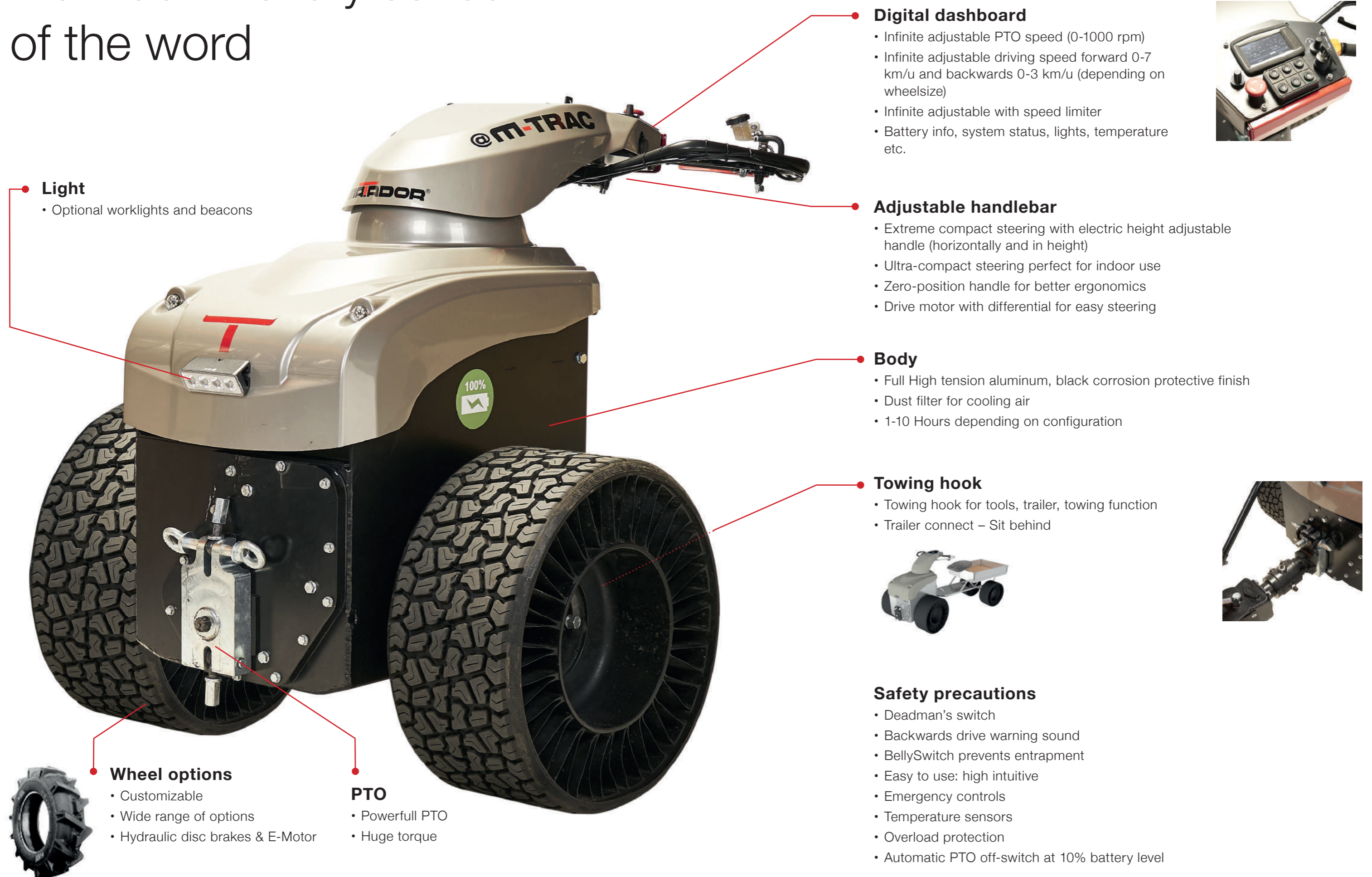

- **Light**
 - Optional worklights and beacons

- **Digital dashboard**
 - Infinite adjustable PTO speed (0-1000 rpm)
 - Infinite adjustable driving speed forward 0-7 km/u and backwards 0-3 km/u (depending on wheelsize)
 - Infinite adjustable with speed limiter
 - Battery info, system status, lights, temperature etc.



- **Adjustable handlebar**
 - Extreme compact steering with electric height adjustable handle (horizontally and in height)
 - Ultra-compact steering perfect for indoor use
 - Zero-position handle for better ergonomics
 - Drive motor with differential for easy steering

- **Body**
 - Full High tension aluminum, black corrosion protective finish
 - Dust filter for cooling air
 - 1-10 Hours depending on configuration

- **Towing hook**
 - Towing hook for tools, trailer, towing function
 - Trailer connect – Sit behind



- **Wheel options**
 - Customizable
 - Wide range of options
 - Hydraulic disc brakes & E-Motor



- **PTO**
 - Powerfull PTO
 - Huge torque

- **Safety precautions**
 - Deadman's switch
 - Backwards drive warning sound
 - BellySwitch prevents entrapment
 - Easy to use: high intuitive
 - Emergency controls
 - Temperature sensors
 - Overload protection
 - Automatic PTO off-switch at 10% battery level

Available wheels

Matador provides with customizable wheels with hydraulic brakes and a wide range of options.

Article Number	Article name	Description	
11015	Michelin 1.1" Wiel	22x11N12, puncture proof	
10736	Michelin 2.2"Wiel	24x12N12, puncture proof	
13246	M-@M-TRAC WIEL 5-12	4PR TT TR128 axle Profile, pneumatic tire	
13266	M-@M-TRAC WIEL 5.70-12	6PR 94 A2 TL SG-813, pneumatic	
13506	M-@M-TRAC WIEL 6.00-9	14 PR TT S-369, pneumatic	
13515	M-@M-TRAC WIEL 155/70	R13 Boka Trailer Line 79 N TL FT01, pneumatic	

Tools for the universal attachment adapter

Recommended tools are all available at Matador B.V.
Choose your tool and turn your M-Trac in whatever you need!

M-Trac Tools	Lipco Tools with recommended PTO speed
Item no.	Description
13519	Adapter Agria Lipco
13629	Adapter Agria BCS

13704	M-@M-TRAC-Multi Puropse Harrow UK-90
13705	M-@M-TRAC-Double Gyration Grader KP-125
13892	M-@M-TRAC-Weed Extractor WB-60 (single)
14036	M-@M-TRAC-Weed Extractor WE-90 (double)
14056	M-@M-TRAC-Weed Extractor with trim lines WEF-165 (double, hooded)

14282	M-@M-TRAC-Pathway Weeder WP-90
14352	M-@M-TRAC-Vertical Flail Machine VS-80
14500	M-@M-TRAC- Sickle Mulching Machine VS-L VS-80
14501	M-@M-TRAC-Mowing Bar Machine MA-80
14502	M-@M-TRAC-Cutterbar UM-137

14503	M-@M-TRAC-Combi Sweeper KM-120 (combi)
14504	M-@M-TRAC-Combi (Snow) Sweeper BU-GROB (coarse)
14505	M-@M-TRAC- Combi (Snow) Sweeper BU-FEIN (fine)
14506	M-@M-TRAC- SnowPlough RS-150
14507	M-@M-TRAC-Snow Thrower SE-100
14508	M-@M-TRAC-Salt, Gravel and Sand Spreader SA50-400
14833	Leaf Blower



M-Trac 2.0

Walk-Behind Multitool

100%
electric

0%
emission, noise
or vibration

MAIADOR[®]
MADE IN HOLLAND



rtmachinery.co.uk
LINKING VALUE WITH SERVICE

01844 299 037 | sales@rtmachinery.co.uk
RT Machinery Ltd, Brackwell Farm Estate, Winchendon Rd,
Nether Winchendon, Aylesbury, HP18 0DS, United Kingdom